



FEATURES

- Popular product enhanced to include even more features!
- Automatically senses mains (utility) failure and starts the backup generators (controlled by DSE model 5510 controllers).
- Automatic 'hours run' balancing of the generator sets.
- Starts and stops sets as the load requires or run all at once.
- Multiple mains supply support to allow the gensets to provide backup and no-break return to multiple mains supplies.
- Allows precise changes to be made to the generator bus/mains supply load share (import/export control)
- Can maintain a specific mains (utility) or generator power factor.
- ATS and Peak lopping control for 5510 controlled generator bus.
- Will synchronise multiple 5510 controlled gensets with the returning mains (utility) supply to provide no-break changeover back to the mains supply.
- 'Soft transfer' (load ramping) both to and from the generator supply.
- Can be used to load test the synchronised generator bus without removing power from the load.
- Clear, backlit LCD display to show the status of the load switches, and mains (utility) supply as well as to indicate alarm conditions should they occur.
- Integral, configurable starting and stopping timers.
- Configurable inputs and outputs to help meet complex specifications.
- Integral log for viewing event history.

INSTRUMENTATION

The 5560 module provides the following instrumentation LCD displays, accessed via the LCD PAGE and DISPLAY SCROLL push buttons:

- Bus Volts (L1-N, L2-N, L3-N)
- Bus Volts (L1-L2, L2-L3, L3-L1)
- Bus Hz
- Bus kW % of full capacity
- Bus kVA % of full capacity
- Bus phase sequence
- Load Amps, pf
- Load kW, kVA, kVAh
- Mains Volts (L1-N, L2-N, L3-N)
- Mains Volts (L1-L2, L2-L3, L3-L1)
- Mains Hz
- Mains Amps
- Mains kW
- Mains kW % of full capacity
- Mains kVA
- Mains pf
- Mains kVAh
- Mains kVAh % of full capacity
- Mains kWh
- Mains kVAh
- Mains kVAh
- Mains phase sequence
- Synchroscope
- System battery voltage

DESCRIPTION

The Model 5560 is an Automatic Transfer switch and Mains controller with comprehensive instrumentation and load control features.

The module is used to monitor a mains supply and automatically start and stop the system's generating sets (controlled by DSE 5510 load sharing controllers). It indicates the operational status by means of an LCD display, and LEDs on the front panel.

The system is used to 'manage' the generator bus, which is fed by DSE 5510 load sharing controllers.

The 5560 instructs the 5510 controllers to make precise changes to the generating set outputs which can be used in many applications including:

- Peak lopping. The generating sets are used to ensure the mains load is kept below a specific, configurable level including automatically starting the sets when the mains level rises above this level.
- No-break return to mains supply. The generator bus is voltage matched and synchronised with the returned mains supply to allow transfer back to mains with no break in supply to the load.

Selected operational sequences, timers and alarms can be altered by the customer. Alterations to the system are made using the 810 interface and a PC. This interface also provides real time diagnostic facilities.

Operation of the module is via pushbutton controls (with security locking facility) mounted on the front panel with STOP/RESET, AUTO, TEST, MANUAL and START functions. The first four pushbuttons feature LED 'selected' indications. Further pushbuttons provide MUTE/LAMP TEST, LCD PAGE, DISPLAY SCROLL and LOAD SWITCHING control functions.

The module features 32-Bit Microprocessor control and a comprehensive list of timers and pre-configured sequences. User configurable expansion facilities are also provided.

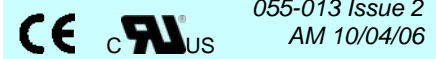

055-013 Issue 2 AM 10/04/06



SPECIFICATION

DC Supply: 8V to 35V Continuous. Able to survive 0V for 50mS, providing supply was at least 10V before dropout and supply recovers to 5V. This is achieved without the need for internal batteries.

Max. Operating Current: 460mA at 12V. 245mA at 24V.

Max. Standby Current: 375mA at 12V. 200mA at 24V.

Generator bus Input Range: 15V(L-N) to 277V(L-N) AC (+20%)

Generator bus Input Frequency: 50Hz - 60Hz at rated engine speed (Minimum: 15V AC L-N)

Mains Sensing Input Range: 15V(L-N) to 277V(L-N) AC (+20%)

Mains Sensing Input Frequency: 50Hz - 60Hz (Minimum: 15V AC L-N)

Auxiliary Relay Outputs: 5A DC at supply voltage.

Generator bus loading Relay Output: 8A AC 250V – normally open.

Mains loading Relay Output: 8A AC 250V – normally closed.

Mains (utility) C.T. Burden: 0.5VA

Operating Temperature Range: -30°C to +70°C

Dimensions: 240mm x 172mm x 57mm (9.45" x 6.77" x 2¼") Panel cutout: 220mm x 160mm (8.7" x 6.3")

The 5000 series modules have been designed for front panel mounting. The module is fitted into the cut-out with the fixing clips removed. These are then fitted from the rear. Connection is via locking plug and socket connectors.

# CASE DIMENSIONS

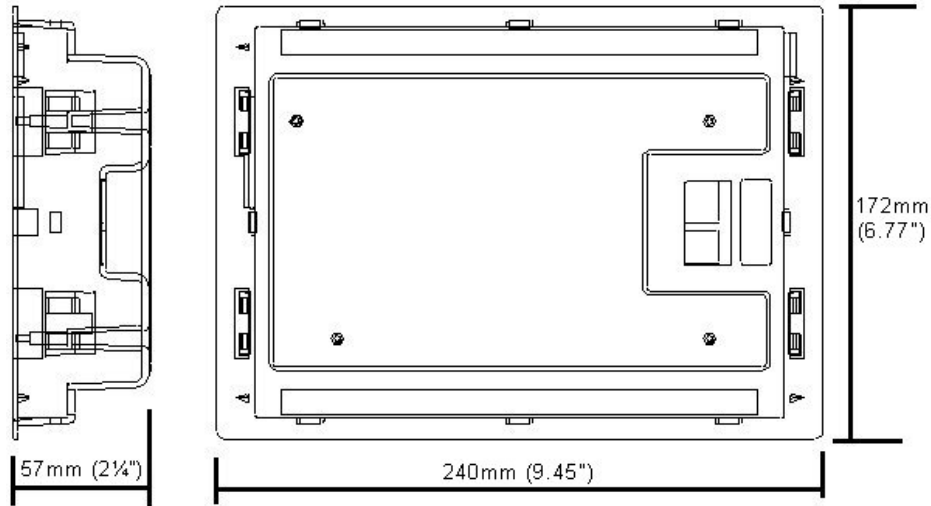

Panel cut-out 220mm x 160mm (8.7" x 6.3")

# TYPICAL WIRING DIAGRAM

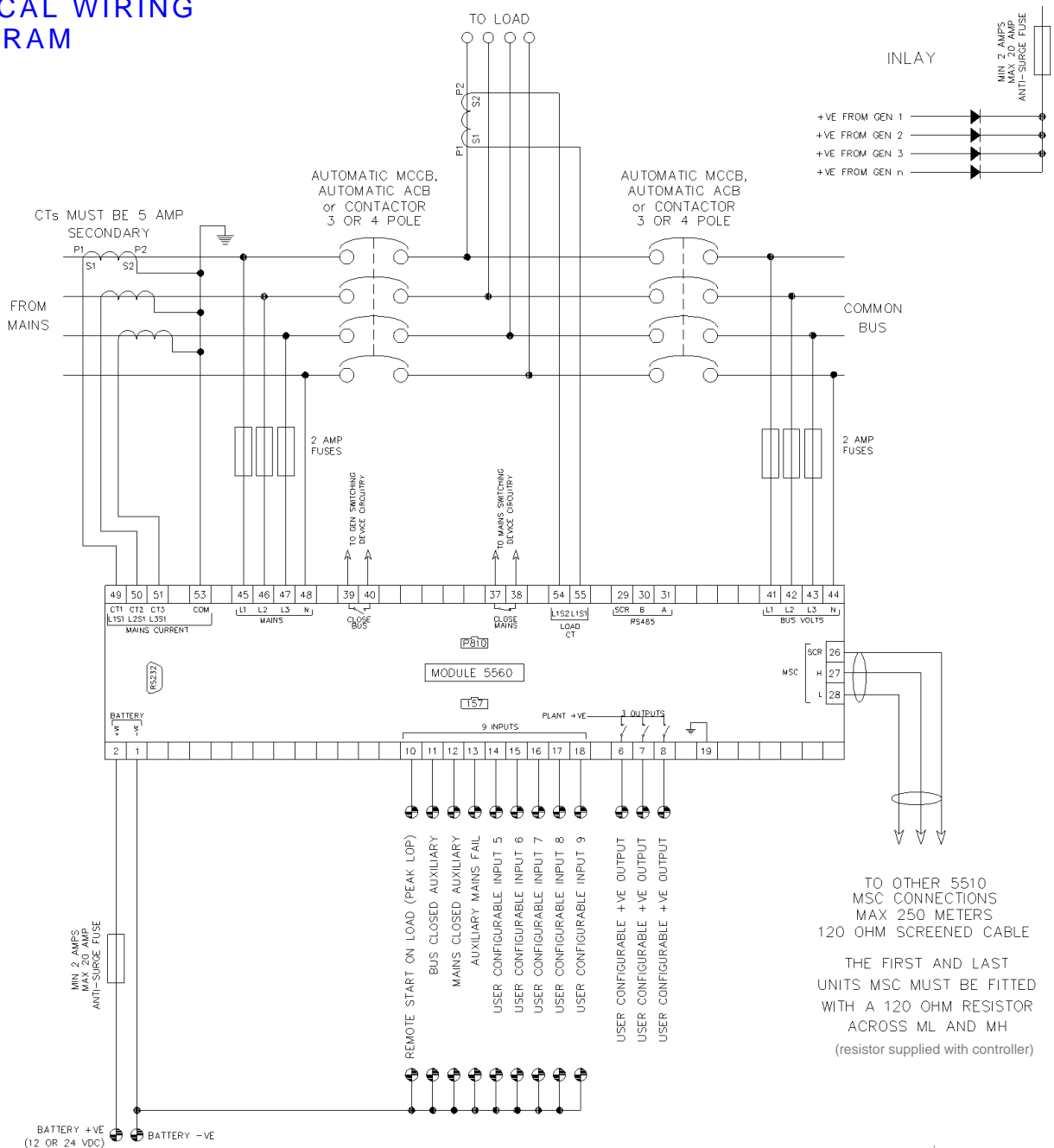

**Deep Sea Electronics Plc.**  
 Highfield House, Hunmanby Industrial Estate,  
 North Yorkshire. YO14 0PH. ENGLAND  
 Tel +44 (0)1723 890099. Fax +44 (0)1723 893303.  
 LO CALL (from UK BT landlines) :  
 Telephone 0845 260 8900. Fax 0845 260 8901  
 Email - sales@deepseapl.com  
 Web - www.deepseapl.com

**Deep Sea Electronics Inc.**  
 3230 Williams Avenue  
 Rockford, Illinois 61101-2668, U.S.A  
 Tel +1 (815) 316-8706. Fax +1 (815) 316-8708.  
 TOLL FREE (USA only) : Telephone 1 866 636 9703  
 Email: dsesales@deepseausa.com  
 Web: www.deepseausa.com